

OPERATION MANUAL

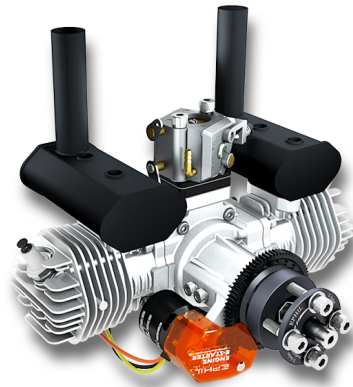

***TWO-STROKE
GASOLINE ENGINE
FOR MODEL AIRCRAFT***

X - 40cc - T **PRO**

Thank you sincerely for purchasing EPHIL® brand series products.

Your support and trust are the main driving force for our team to carry out product innovation and development.

Excellent engine performance will be your reward. Hope you like this engine and enjoy your play!

*** Before attempting to operate the engine, please read the general 'SAFETY INSTRUCTIONS AND WARNINGS' in the following sections and strictly adhere to the advice contained therein.**

Table of contents

Safety Instructions and Warnings.....	1
Components.....	3
Specifications.....	4
Installation of the Engine.....	4
Installation of Circuit and Ignition Unit.....	6
Carburetor Adjustment.....	7
Fuel.....	8
Fuel Tank and Lines.....	8
Preparation Prior to Start.....	8
Engine Running-In.....	8
Starting The Engine.....	9
Engine Maintenance.....	10
Troubleshooting Guide.....	10
Dimensions.....	12
Exploded View and Parts List.....	13

Safety Instructions and Warnings

• Remember that your engine is not a " toy ", but a sophisticated hobby product, a highly efficient internal combustion machine. This product must be operated with caution and common sense and requires some basic mechanical ability. Failure to operate this product safely and responsibly could result in injury or damage to your or other's body, health, and properties. Before operating the engine, the safety of the surrounding environment and personnel shall be confirmed. Always remember to put your and other's safety in the first place.

• Disclaimer: The user-self shall be responsible for the consequences caused by the following cases: children under 14 years old who operate this product; operating the engine without reading the instruction manual; ignoring or not following the safety instructions and warnings on this instruction manual or EPHIL official website; applying unauthorized disassembly or modification on this product without the authorization of the manufacturer.

Age Recommendation: Not for children under 14 years. This is not a toy!

Warnings

- Improper or wrong operation of the engine may cause serious physical injury, please use it carefully!
- This is a special engine that is engineered for model aircraft, please do not refit the engine and put it in use for other purposes.
- Before starting the engine, please make sure all components including the propeller and the engine mount are secure and tight. It is strongly recommended that a good quality screw sealant is used during engine installation.
- Always mount the engine securely on a bench mount or high-quality engine mount.
- When you install the engine, must ensure the correct size and pitch of the propeller for your engine; must ensure the correct size and distance of the drilled mount hole.
- Always ensure that the propeller is securely attached to the engine shaft and all retaining fasteners are tightened properly before EACH flight.
- Never get close to the running propeller.
- Never try to stop the engine physically. And never put other matters into the rotating propeller.
- Never use hands, fingers, or any other body part to stop the propeller.
- Never attempt to repair or modify a propeller beyond its intended use.
- Never stand in front or in line with the propeller when the engine is running. Keep onlookers away (at least 30 feet) from the running engine, especially children.
- Always use a balanced spinner and a balanced propeller. An unbalanced spinner and propeller combination will cause high levels of vibration and may cause the propeller shaft to break. Securely tighten the spinner and propeller on the engine to prevent it from being thrown off the engine while running.
- Never use a nicked, cracked, or split propeller. Never use a propeller that has hit the ground. Even though it may look good from the outside, it may be cracked on the inside which may cause it to disintegrate while in use.
- Keep foreign objects away from the propeller. Make sure that nothing can be "sucked in" by the propeller.
- Never run the engine in the vicinity of loose small objects, such as gravel or sand, to avoid the propeller uncontrollably throwing such materials.
- Never wear loose clothing or a loose neck strap when

operating your model engine as these items could become entangled in the propeller.

- Never attempt to flip the propeller when the engine has just stopped. Immediately after a glow plug-ignition engine has been run and is still warm, conditions sometimes exist whereby it is just possible for the engine to abruptly restart if the propeller is casually flipped over compression WITHOUT the glow plug battery being reconnected.
- Never have loose objects such as screwdrivers, pencils, etc. in your pockets when operating your model engine. These could fall into the propeller.
- Always keep small parts out of the reach of children as they can be choking hazards.
- Never operate this engine after drinking or taking drugs. Alcohol and drugs may affect your judgment and perception of potential dangers.



- Never touch the engine and its components with your bare hands or other body parts while the engine running or just after a run. The engine will remain very high temperature.



- Gasoline is highly flammable. Always keep away from open flame, excessive heat, sources of sparks, and other inflammable and explosive materials. Never smoke near gasoline.



- The gasoline used for the engine is a toxic chemical, if swallowed, in contact with skin, or inhaled, it can cause damage to organs. be careful with its hazards when you use it. Always avoid children's contact.

- Never run your engine in a closed space to avoid potential hazards by inhalation of engine exhaust and carbon monoxide. Please run the engine in a well-ventilated open area.
- When using, transporting, and storing gasoline, it is necessary to know the relevant local laws and regulations of the country or region. And you shall report the gasoline usage to the local fire department in advance if necessary.
- Always store your fuel safely in a sealed, water-resistant container. Always store fuel in a cool, dry location.
- Always ensure the fuel is stored in a clearly marked container well away from the reach of children.

Notes

- Always perform a safety and functionality check prior to each flight.
- Refilling the fuel tanks only after the engine is well cooled down.
- Be sure to use the silencer (muffler) supplied with the engine. Frequent exposure to an open exhaust may eventually impair your hearing.
- Always wear safety glasses or goggles when starting and running your engine.
- Always cut off the fuel supply (pinch or disconnect the fuel line to the carburetor) or use the throttle linkage to shut off the air in order to stop the engine.
- It is strongly recommended to use a suitable electric starter.
- When your electric starter does not work properly, is damaged or has impurities attached to the gear, please stop using it.
- Please Use an appropriate tool or a folded piece of cloth to remove the glow plug/ spark plug instead of bare hands.
- Always stand behind the propeller when making carburetor adjustments.
- Make sure the fuel line is well-secured to the engine and to the fuel tank so that it won't come off in flight.
- Excessive running of the engine at idle speed can result in reduction of the service life of the glow plug/spark plug.
- Use gasoline-approved vinyl or neoprene rubber fuel line instead of silicone fuel line because it will be dissolved by the fuel. Always secure the fuel line away from the cylinder. The heat from the engine can damage the fuel line.
- Keep the surface of the engine clean to ensure proper heat dissipation. Ensure proper cooling/ventilation around the cylinder with adequate air exhaust.
- Before transporting your model airplane, remove all the fuel from the fuel tank and fuel lines.
- Always use high-quality oil intended for 2-stroke (2-cycle) engines. A high-quality synthetic 2-cycle oil is recommended for optimum performance and longer engine life.
- Keeping gasoline inside the carburetor over an extended period of time will damage the diaphragm valve and clog passages inside the carburetor. If the engine is not to be used for more than a month, drain the fuel tank and remove any fuel from inside the carburetor.
- Use a filter intended to be used with gasoline engines.
- Always follow local policies and regulations when using engines and model aircraft. Also it is recommend that fly in accordance with the safety runs, regulations, and recommendations of the AMA (American Modeling Association).

Components

40cc Engine	X-40cc-T	X-40cc-T Pro
Engine	✓	✓
Walbro Carburetor	✓	✓
Muffler Set (L & R)	✓	✓
CM6 Iridium Spark Plug x 2	✓	✓
Electronic Ignition	✓	✓
Aluminum Standoff Set	✓	✓
Gear-Drive Propeller Hub		✓
Engine Starter		✓
Starter ESC		✓

Specifications

Model: X-40cc-T Pro

Displacement	40cc (2.44 cu in)	Ignition Voltage	6-14 V
Performance	4.6 HP	Spark Plug Type	CM6 Iridium Spark Plug
Speed Range	1800-8300 RPM (Test Propeller-20*8)	Recommended Propeller	20x8; 20x10; 19x8; 19x10
Bore	32 mm (1.26 in)	Weight of Main Engine	1190g
Stroke	27mm (1.06 in)	Weight of Muffler Set	136g (L&R Mufflers; Screws)
Static Thrust	11.5 kg 100 m ALT (25.4 lb @ 328 ft ALT)	Weight of Engine Mount	84g
		Weight of Spark Plug	13.5g *2 (CM6*2)
Static Thrust	9.0 kg @ 1800 m ALT (19.8 lb @ 5900 ft ALT)	Weight of CDI (Ignition)	175g
		Weight of Starter	113g
Compression Ratio	9:1	Weight of ESC	36g
Lubrication Ratio	30:1 (Fuel: 2-Stroke Motor Oil)	Total Weight	1786g (3.94 lb)
Fuel:	Gasoline	Engine Stroke Type:	Two-Stroke
Engine Cooling:	Air Cooling	Cylinder:	Twin Cylinder
Air Intake:	Naturally Aspirated via Carburetor	Crankshaft Material :	Chrome Moly Steel
Carburetor:	Walbro	Main Engine Material:	High Quality Aluminum Alloy

Installation of the Engine

Muffler Installation

- Using an Allen key to install the muffler onto the engine cylinder.
- Be sure to place a muffler gasket between the muffler and the engine cylinder.
- This muffler can be adapted to the smoke system.
- Be sure to keep the screw on the side threaded hole of the muffler installed if the smoke system is not needed.
- To install a smoke system, refer to the diagram on the right. First, remove the screw on the side threaded hole, and then use a wrench to tighten the brass fuel port inside the packaging into the reserved threaded hole.

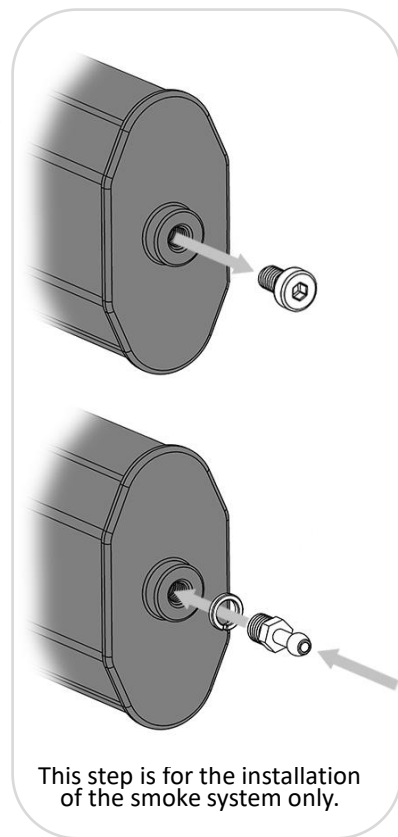
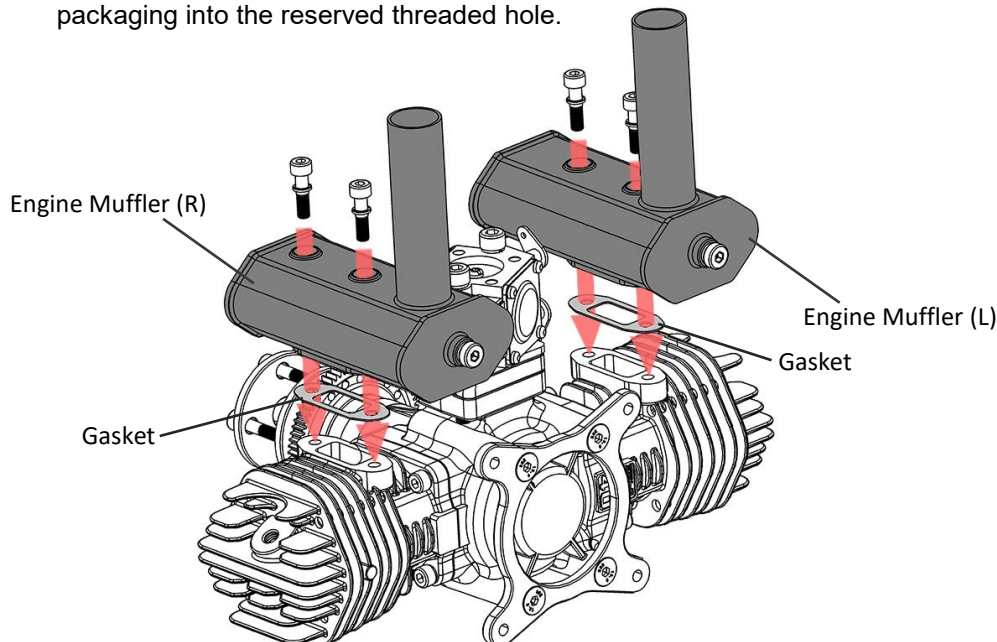

Engine Mount Installation

- The 40cc engine applies 4 Aluminum standoffs to mount the engine.
- Thread the screw through the aluminum standoff and use a nut to lock the screw on the back of the firewall.
- Apply appropriate and equal torque when installing bolts and ensure that the installed bolts do not loosen.

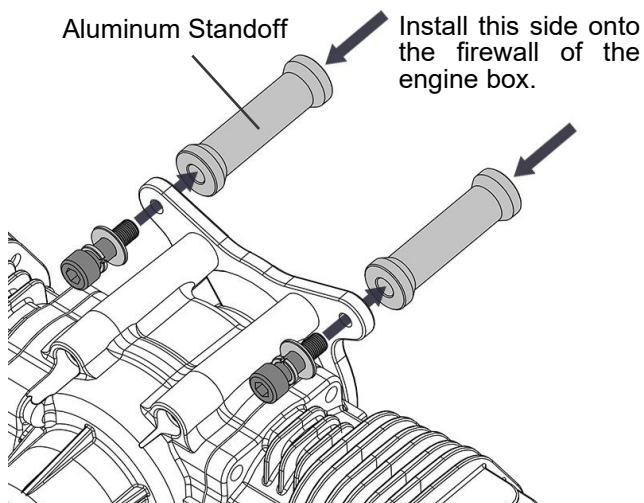

Spark Plug Installation

- Tighten the spark plug to the spark plug port on the top of the cylinder using a hex socket wrench.
- Firmly press the spark plug cap onto the spark plug and ensure good contact.
- Turn off the power switch before connecting the ignition module and the spark plug to avoid the potential electric shock hazard.

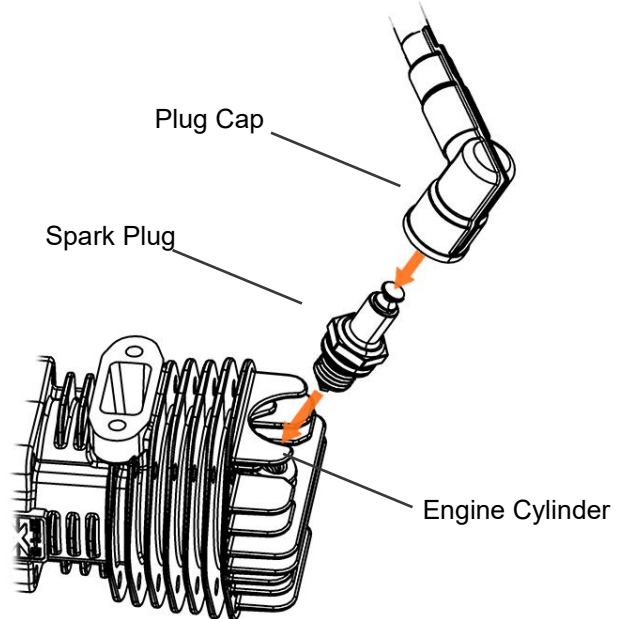

Propeller Installation

- For a 40cc engine, it is recommended to use a 20x8 wood/carbon fiber 2 blade propeller.
- The selection of propeller is not fixed, the type of propeller applied should depend on the design and weight of the aircraft as well as the type of aircraft.
- It is recommended to use a slightly smaller propeller during the engine running in period.
- When installing the propeller, ensure that the nut is tightened.
- You may need to use an electric drill to drill holes in the purchased propeller. Pay attention to safety when drilling holes. Ensure that the position and size of the holes are correct and perpendicular to the plane.
- Be sure to use a balanced propeller. Do not use any propeller that has become split, cracked, or nicked even very slightly, or received a strong impact even if no apparent damage is visible.

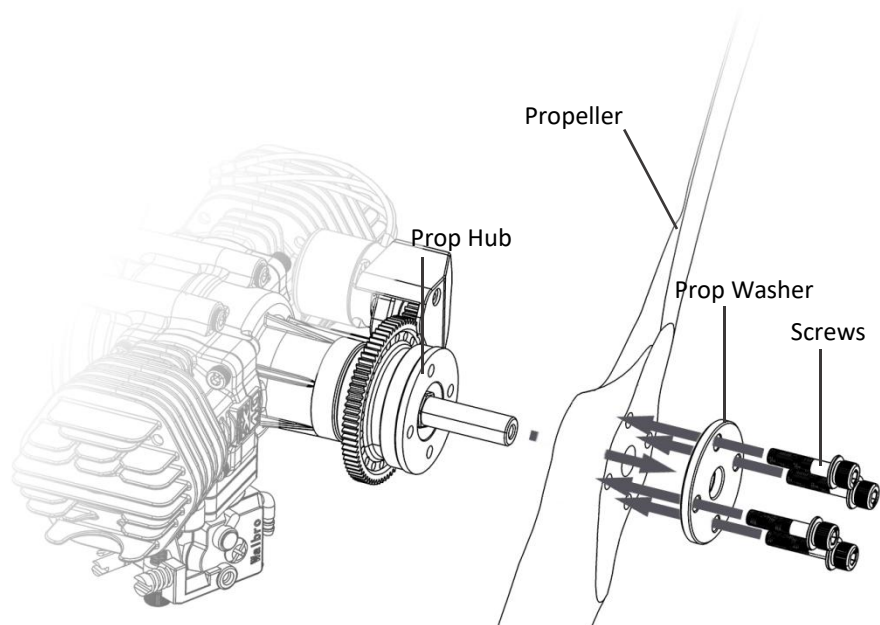

Make sure that the size of the drilling holes has correct size. The diameter of the holes is about 5.1-5.2mm.

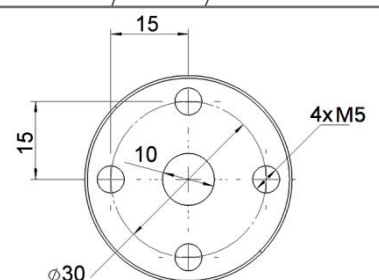

Installation of Circuit and Ignition Unit

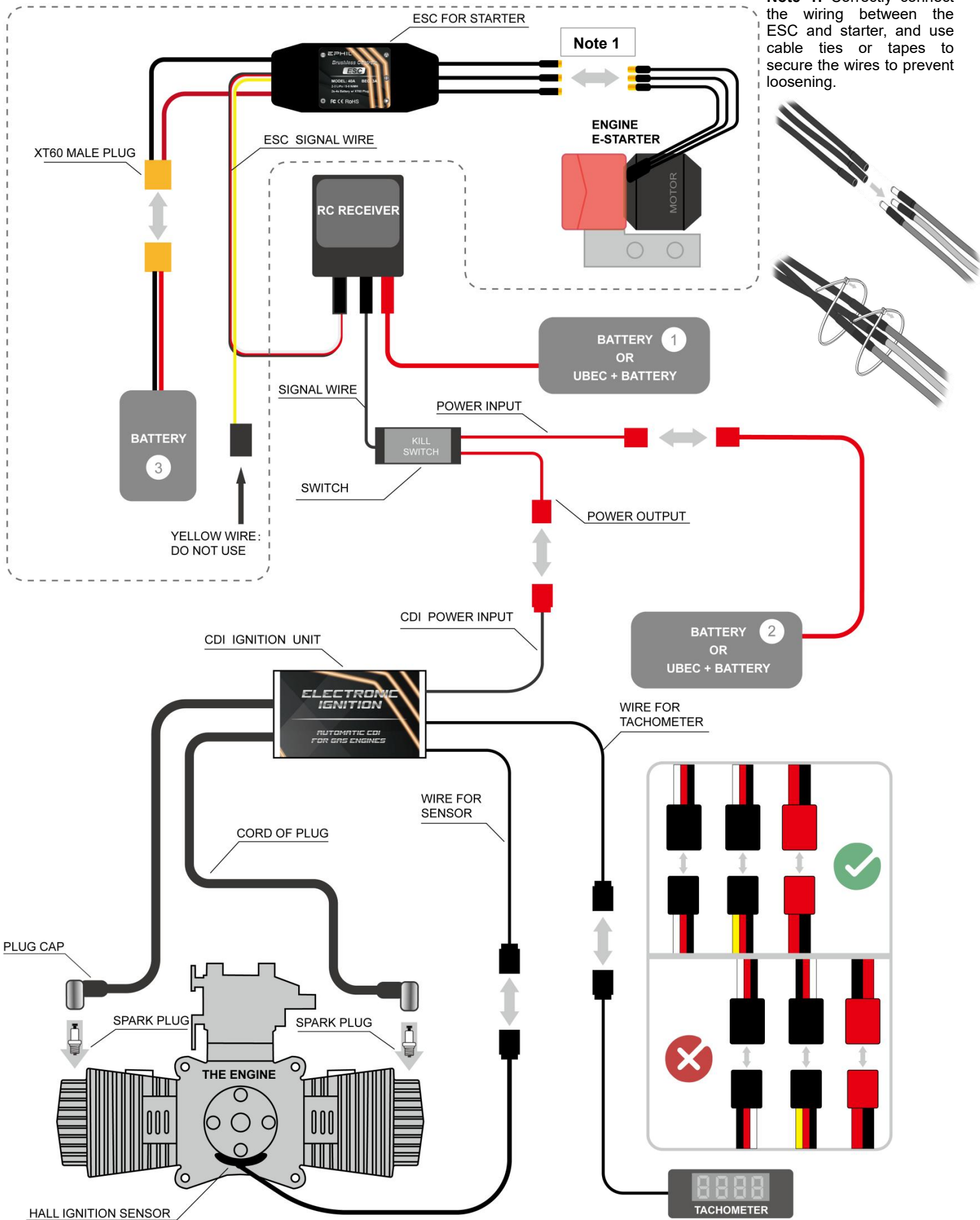

NOTE:

- **Voltage input:** 1. CDI ignition(Battery ②): 6V-14V; 2. ESC for engine starter (Battery ③): 11.1V,600-1000mAh
- This figure is an overview of the circuits related to the installation of the engine. EPHIL engine does not include the battery, kill switch, receiver, and tachometer. The plug locations, types, and colors of the aforementioned electronic products from different brands you purchase may vary. Please refer to the guide and instructions for the specific electronic products and install the circuit correctly!
- Please install those plugs correctly refer to the diagram above, and ensure that the positive and negative poles and wiring colors are correctly matched (red wire: positive pole; black wire: negative pole). Otherwise, the ignition module might be damaged.
- It is necessary to correctly connect the Hall ignition sensor wiring to make the engine work properly.

- To prevent any unwanted interference. Please install the ignition module and its power source as far as possible away from the servos and receiver power source.
- Ensure that the high-voltage wire sheath does not come into contact with the engine and fairing to avoid accidental short circuits.
- To ensure the stable operation of the ignition system, please install the ignition module taking sufficient anti-vibration measures.
- Using some incompatible electronic products (such as an incompatible tachometer) may cause the engine to fail to start.
- **For safety considerations. The power supply to the ignition module and starter motor must be cut off before ending the engine operation and turning off the remote controller. This step will help to avoid accidental engine starting.**

Carburetor Adjustment

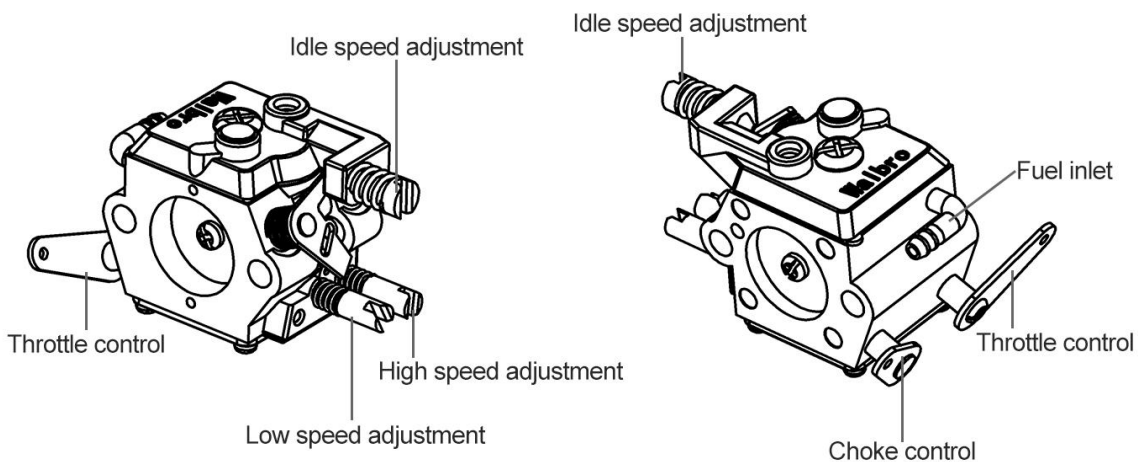

- The carburetor is one of the core components of the engine and directly affects its performance and power. For safety reasons, it is not recommended to disassemble or modify the carburetor, and it is not recommended to adjust the idle screw.
- The engine has been adjusted to the optimal state (default setting) for low and high speed needles at the factory.
- Based on the altitude and the operating conditions of the engine, you can adjust the low-speed and high-speed needles slightly within a small rotation range to achieve optimal performance of your engine.
- When adjusting the low and high speed needles of the carburetor, use a flat headed screwdriver to tighten the two needles clockwise to the reset state, and then rotate the pointer counterclockwise according to the parameters in the table below to the specified number of turns.
- Before adjusting the carburetor, you **MUST** stop the engine.

Engine	Carburetor	Low-Speed Needle	High-Speed Needle
X-40cc-T (& Pro)	Walbro WT978 B	1 Turn 12 Minutes (1.2 Turn)	1 Turn 48 Minutes (1.8 Turn)

Fuel

- Fuel / Oil mixing: 1 Gallon Gasoline (128 fl oz/3.78L) : 2-Cycle Oil (4.26 fl oz/125.68ml) = **30:1 Ratio**.
- At running-in process: Gasoline : 2-Cycle Oil = **25:1 - 28:1 Ratio**.
- Fuel: High-quality RON95 unleaded gasoline (Euro 95 / Midgrade gasoline) is recommended.
- Lubricating Oil: High-quality 100% synthetic 2-cycle oil is recommended. (Motul 800 2T 100% Synthetic racing motor oil; STIHL Ultra High Performance 2 Cycle fully synthetic Engine Oil; DELUXE Materials R/C Specific full synthetic 2 stroke oil etc)
- Never use outboard motor 2-cycle oil.

Fuel Tank and Lines

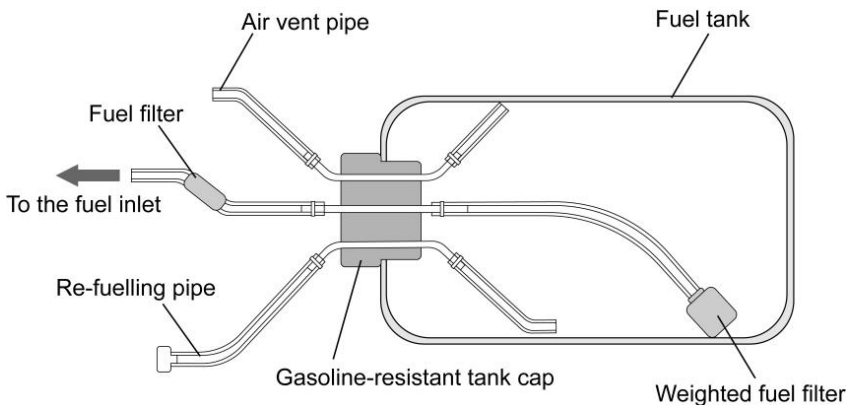

- Be sure to use a fuel tank and fuel pipe which are compatible with gasoline.
- Be sure to use gasoline-resistant tank cap.
- Be sure to check and replace the fuel pipe periodically.
- Be sure to apply a commercially available gasoline fuel filter at the fuel pipe.
- Be sure to check and clean the fuel filter periodically.

Preparation Prior to Start

- Ensure the safety of the environment and ensure that surrounding personnel are at a safe distance.
- Check the circuit of the ignition system to ensure that the circuit connections are correct and secured.
- Make sure the propeller is securely attached to the engine shaft and all retaining fasteners are tightened properly before the flight.
- Check the tightness before and after every flight of the aircraft, make sure that the installation of the engine mount between the engine and the aircraft is secure and there are no loose bolts.
- Check the integrity of the propeller. Make sure the propeller is securely attached to the engine shaft.
- Make sure the radio control system works normally.
- Make sure that the battery is fully charged.
- Check the carburetor to make sure the throttle and choke are working well.
- Make sure the fuel line is connected securely to the carburetor.
- Check the fuel tank and fuel lines. Make sure they are connected correctly and securely.
- Make sure that there is sufficient fuel in the fuel tank to complete the flight.
- Warm up before each flight.

Engine Running-In

- The proper engine running-in will optimize the internal mechanical coordination of your engine, contributing to optimal power performance and an extended lifespan. Do not skip this step!
- The best way to break in the engine is through a hot run-in, which involves starting the engine normally for the break-in process. This is because the inside of the cylinder expands and contracts with heat, achieving the best break-in effect. Improper engine start-up for the break-in or cold running-in, due to low temperatures, can cause abnormal wear between the piston rings and the cylinder wall. Abnormal break-in can lead to excessive wear, affecting the piston's airtightness and ultimately resulting in a decrease in power.
- The engine should be run installed in the airframe with

wings attached or an engine test bench.

- It is recommended to use a smaller propeller during the running in process.
- During the running-in process, the carburetor may need to be adjusted and the engine should be run at light load and varying speed for enough time to have the oil run through the internal part.
- The fuel used during engine running-in process should be 25:1 - 28:1 ratio (gasoline:2-Cycle Oil). After you have run a couple of gallons of fuel through, you can switch to a ratio of 30:1.

Starting The Engine

Manually Starting

- Turn the transmitter and receiver switches ON.
- Have someone help you to hold the airplane while you start it.
- Switch the ignition to ON, close the choke plate on the carburetor, and open the throttle slightly from the idle position.
- Make sure you use a good quality, lightweight aluminum spinner. Make sure you use a thick glove to protect your hand. Use your electric starter to turn the propeller hub over for several seconds (counterclockwise), or flipping a propeller rapidly. Until a popping sound is heard and the propeller is spinning. This indicates that the engine is successfully started. Stay away from the engine and propeller immediately!
- Starting the engine for the first time may be difficult, please be patient and try more times.
- If the engine still will not start, unscrew the spark plug and check its contacts. Clean any possible excess fuel inside the cylinder and try again.
- Let the engine idle for 30 to 50 seconds after the engine successfully starts.

To start a Pro version engine, which comes with an electric starter configuration. It is very easy and safe to start your engine with this remotely controlled electric starter. Starting an engine with an electric starter is highly recommended. The contents on the right side are the procedures to start the Pro version engine.

- During the engine running-in process, it is necessary to have good ventilation conditions to ensure effective heat dissipation for the engine.
- During the engine break-in process, avoid rapidly increasing or decreasing the throttle, and refrain from running at high speeds for long periods.
- Running-in time: On-ground running: at least 2 hours; Flight running: at least 5 hours.
- Running-in speed: Low speed: 20%; Medium speed: 60%; High speed: 20%.

Remote Controlled Starting (For EPHIL Pro Version Engine)

- Turn the transmitter and receiver switches ON. And make sure the ignition module is powered off.
- Connect the three wires on the motor of the electric starter to the three wires on the ESC (electronic speed controller), and then insert the ESC signal wire into an available switch channel on the receiver.
- Connect the power wires of the ESC to the battery. It is recommended to use a 4S Lithium polymer battery with a capacity below 1000mAh (this battery should have an XT60 female connector). Hearing 3 times beeping sounds from the ESC indicates a correct connection.
- For the first time using the EPHIL electric starter. Turn on the corresponding switch on the remote controller for 1-3 seconds. If you observe the propeller rotating counterclockwise, it indicates that the circuit is installed correctly. Otherwise, immediately cut off the power to the ESC, then interchange the connection of any two wires between the motor and the ESC, and try again.
- After completing the above preparations, power on the ignition module, connect the fuel line and stay away from the propeller and the aircraft.
- Turn on the corresponding switch on the remote controller for 1-3 seconds, and the engine will start. After the engine successfully starts, remember to immediately turn off the switch. The engine will keep running!

Engine Maintenance

- Check the tightening of each screw often, especially engine installation screws and muffler installation screws before and after a flight. Engine vibration during running may cause screws to loosen. Tighten the screws after each flight.
- Fuel tubing throughout the fuel system should be changed periodically. If the fuel line starts to get hard, soft, or color change, there is a good chance it needs to be replaced. Keep in mind that the tubing inside your tank deteriorates more quickly than anywhere else in the system.
- Check the exterior of the engine to make sure there is nothing wrong and wipe off any oil res and dust. The engine should be kept clean and free of dirt build-up.
- Install a fuel filter to prevent foreign matter in the fuel container from entering the fuel tank. Clean these filters periodically.
- The carburetor fuel screen should be cleaned periodically also. Carefully remove the pump cover, gasket, and pump membrane. The screen will be visible and can be cleaned after careful removal. Professional carburetor cleaning agents might be needed. If ever the carburetor seems to need frequent mixture adjustment or acts like it's starving for fuel, a dirty screen is a likely candidate for a cause. The carburetor should be inspected, cleaned, or reconditioned with every flying season or after being stored for a long period.
- The spark plug should be inspected, and cleaned periodically and replaced if it is fouled or worn. A new plug with every new season is a worthwhile maintenance step.
- Do not disassemble unnecessarily to prevent damage to parts or allow foreign matter to enter the engine.
- When the engine is not to be used for a long period, remove the engine from the model, clean the outside then remove the carburetor, and plug all tubing. Clean inside the engine by rotating the crankshaft with the engine immersed in a container filled with gasoline. After cleaning the engine, dry it well then inject a small quantity of oil used to mix fuel and rotate the crankshaft several times to distribute the oil well inside the engine. Then cleaning the carburetor with carburetor cleaning agents, install it on the engine. And place the engine in a dry place.

Troubleshooting Guide

Failure to start the engine

Possible Causes	Solutions	Repair Kit(s) Needed
<i>Insufficient fuel / insufficient battery power</i>	<i>Refueling / charging the batteries</i>	<i>None</i>
<i>Wrong circuit connection</i>	<i>Check the circuit, especially the installation of the ignition module. Reinstall the ignition module and circuit</i>	<i>None</i>
<i>Spark plug carbon buildup</i>	<i>Check and clean the spark plug</i>	<i>None</i>
<i>Spark plug not working</i>	<i>Replace the spark plug</i>	<i>Spark plug</i>
<i>Hall ignition sensor or wire not working</i>	<i>Replace the Hall ignition sensor</i>	<i>Hall ignition sensor</i>
<i>Ignition module damaged/ not working</i>	<i>Contact after-sales service for repair or replacement, do not attempt to repair it yourself</i>	<i>Repair or replacement needed</i>
<i>Plug cap damaged/ not working</i>	<i>Replace the spark plug cap on the ignition</i>	<i>Spark plug cap</i>
<i>Tachometer incompatibility</i>	<i>Use a compatible tachometer from another brand</i>	<i>Tachometer</i>
<i>Clogging in carburetor</i>	<i>Clean the carburetor and the carburetor fuel screen</i>	<i>None</i>
<i>Carburetor damaged/ not working</i>	<i>Replace the carburetor</i>	<i>Carburetor</i>
<i>Excess fuel in cylinder</i>	<i>Discharge the excess fuel, adjust the carburetor</i>	<i>None</i>
<i>Engine E-starter damaged/ not working</i>	<i>Replace the engine E-starter</i>	<i>Engine E-starter</i>

<i>Gear-drive prop hub damaged/ not working</i>	<i>Replace the gear-drive prop hub</i>	<i>Gear-drive prop hub</i>
<i>Wrong connection between starter and ESC</i>	<i>Check the circuit connection, and reinstall the plugs</i>	<i>None</i>
<i>Engine E-starter has no response</i>	<i>Check the signal wire connection to the receiver or controller setting</i>	<i>None</i>

Abnormal engine running

Situations	Possible Causes and Solutions	Repair Kit(s) Needed
<i>Engine response delay when accelerated rapidly</i>	<i>Try to adjust the carburetor first. Focusing on the low-speed needle 'L', it might be too lean. Open it up about 1/8 of a turn and try again</i>	<i>None</i>
<i>rpm increases at idling</i>		
<i>engine stops when the throttle is moved from high to low</i>		
<i>The idle is not steady</i>	<i>Replace the spark plug / glow plug</i>	<i>Spark plug / glow plug</i>
<i>The idle is not steady</i>	<i>The low-speed needle 'L' valve might be too rich. Close it 1/8 of a turn and try again</i>	<i>None</i>
<i>Engine stops at full throttle</i>	<i>Try to adjust the carburetor first. Focusing on the high-speed needle 'H', it might be too lean. Open it up about 1/8 of a turn and try again</i>	<i>None</i>
<i>Engine response delay when accelerated rapidly</i>		<i>None</i>
<i>Engine will not come up to full rpm at full throttle</i>		<i>None</i>
<i>When turning off the remote controller, the electronic starter is restarting</i>	<i>Cut off the power supply to the electronic starter and ESC before you turn off the remote controller</i>	<i>None</i>
<i>Engine unable to reach full rpm</i>	<i>The high-speed needle 'H' valve might be too rich. Close it 1/8 of a turn and try again</i>	<i>None</i>
<i>Abnormal aircraft shaking</i>	<i>Check if the engine mounting screws are loose and try to tighten all screws</i>	<i>None</i>
<i>Significant decrease in engine power, engine stops, or abnormal noise</i>	<i>Might be: cylinder/ piston scraping, or crankshaft/ connecting rod damaging, or bearings/ needle bearings damaging. These are serious engine failure. Rare happen but should be taken seriously. Stop using and disassemble the engine, inspect the fault point, and replace damaged parts. Or contact after-sales service</i>	<i>Repair and replacement of parts are required, depending on the specific situation</i>

Dimensions

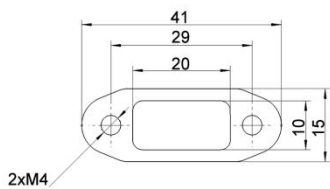
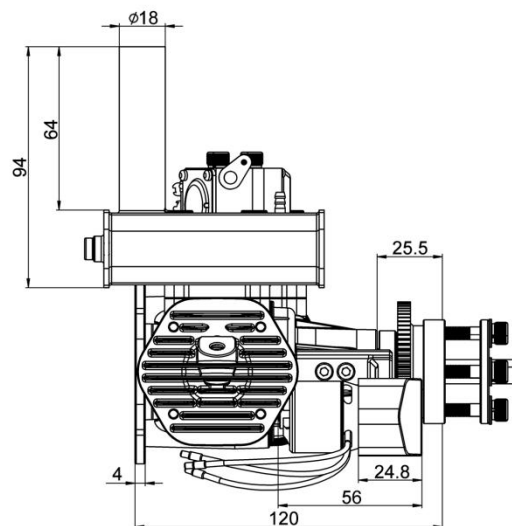
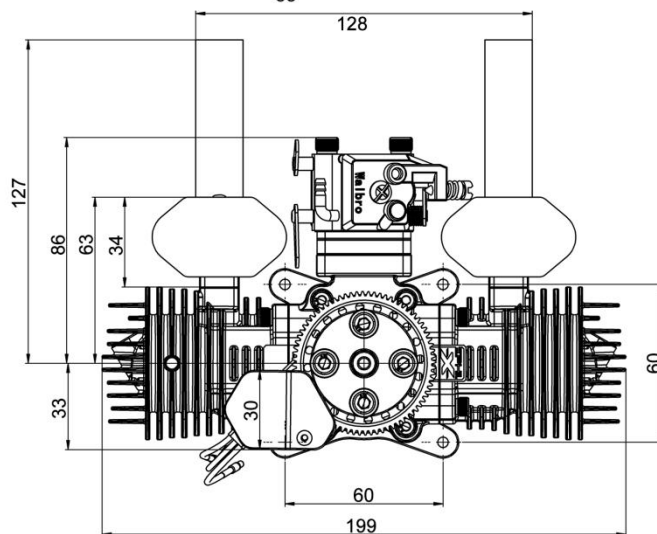
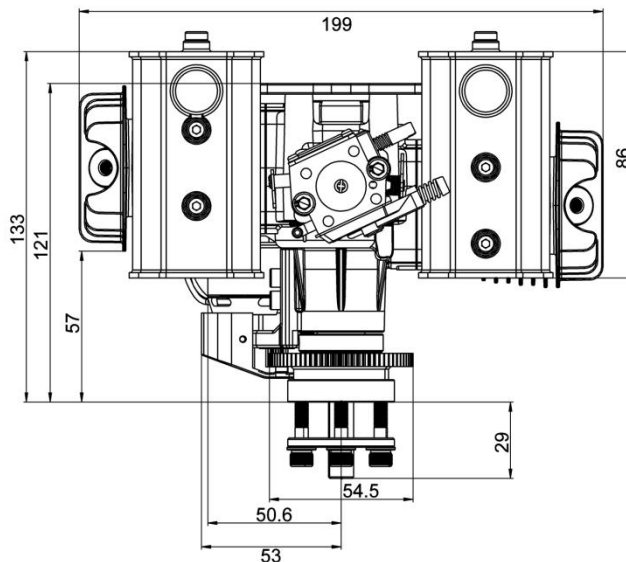

Muffler Interface

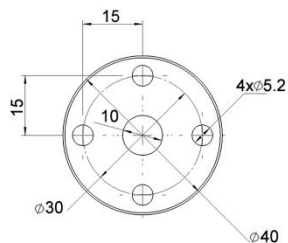

Propeller Drilling

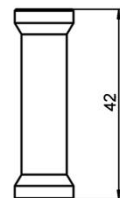

Mount Length

Firewall Drilling (For Engine Mounting):
60mm×60mm; Ø 5.2mm ×4

Exploded View and Parts List

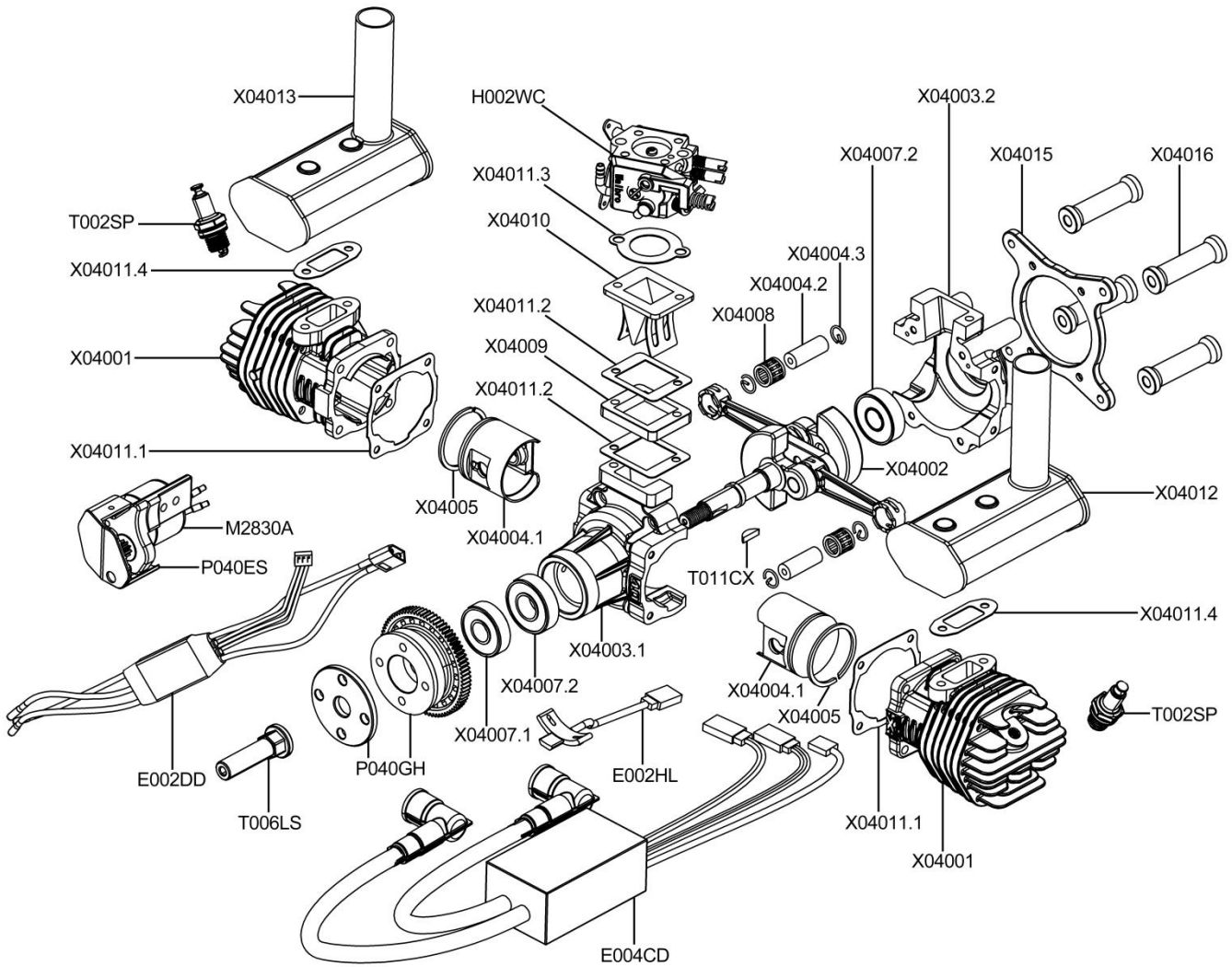

NO.	CODE NO.	Description	NO.	CODE NO.	Description
1	X04001	Cylinder	12	X04011.1	Gasket Set
2	X04002	Crankshaft & Rod		X04011.2	
3	X04003.1	Crankcase Set		X04011.3	
	X04003.2			X04011.4	
4	X04004.1	Piston Accessory	13	X04012	R-Muffler
	X04004.2		14	X04013	L-Muffler
	X04004.3		15	X04015	Bracket plate
5	X04005	Piston Ring	16	X04016	Aluminum Standoffs
6	P040GH	Gear-drive Prop hub accessory	17	T002SP	CM-6 Iridium Spark Plug
7	T006LS	Propeller Jam Nuts	18	H002WC	Walbro Carburetor WT-978 B
8	X04007.1	Bearings	19	E004CD	CDI Electric Ignition Model: C-2.4
	X04007.2		20	E002HL	Hall(M size)
	X04007.3		21	T011CX	Woodruff Key (S size)
9	X04008	Wrist Pin Bearing	22	E002DD	Brushless Motor Speed Controller
10	X04009	Carburetor Base	23	P040ES	E-Starter
11	X04010	Reed Valve & Insulator		M2830A	
				T003LS	Screw Sets
				M2830A	Brushless Motor

Consumer Warranty Policy

Warranty Covers: Warrants to the original purchaser that the product will be free of defects at the time of sale and provides a 12-month warranty for manufacturing faults with the product.

This Warranty only applies to the product purchased through EPHIL authorized distributors or dealers and the official website. Our EPHIL factory provides worldwide warranty service for our Products. Please contact your relative service center or authorized distributors for detailed warranty information or contact us via email:

service@ephilpower.com. Also, we will update our distributor or dealer list periodically.

Warranty Not Covers: The warranty card is not transferable. Warranty does not cover any issues arising from misuse, poor turning, wear and tear, modification of or to any part of the product, crash damage, or faulty /poor or inappropriate installation by the end-user. The ignition (CDI and AET ignition devices) warranty does not include damage caused by supplying too high an input voltage, vibration damage, incorrect circuit connections, or use without a spark plug/glow plug firmly connected. The warranty is void if the product is disassembled without authorization from EPHIL authorized distributors or EPHIL service centers.

The warranty doesn't cover consumable parts such as spark plug; glow plug; piston ring; gears; muffler, etc.

Purchasers Remedy: EPHIL will, at its option, repair or replace any product determined by EPHIL to be defective. EPHIL reserves the right to inspect any and all Product(s) involved in a warranty claim. Service or replacement

decisions are at the sole discretion of EPHIL. Warranty claims must be accompanied by a copy of your original invoice and original warranty card with Matching Serial number.

Warranty Services

Questions, Assistance, and Services: Once assembly, setup or use of the Product has been started, you must contact your local distributor or EPHIL directly. If you have any questions or need help, please visit our website <https://www.ephilpower.com> and contact us by email.

Inspection or Services: If this Product needs to be inspected or serviced and is compliant in the country you live and use the Product in. Please check the Product is still under warranty. Please send a Service Request to service@ephilpower.com, please describe the product you need service and its Matching Serial number, briefly describe the problem you encountered, and provide your complete name, street address, email address, and phone number. You must include the original sales receipt to verify the date of proof of purchase. Provided warranty conditions are met, your product will be repaired or replaced at no charge. Specific maintenance or replacement details will be explained to you in the email.

Non-Warranty Service

If your product is not under warranty, service will be completed and payment required. We will notify you and estimate the cost. Non-warranty service estimates will be billed a minimum of ½ hour of labor. In addition you will be billed for return freight.

EPHIL®

<https://www.ephilpower.com>

EPHIL is a registered trademark of Zhejiang Mcat Technology Co. Ltd, China.
This logo is only available for authorized distributors and businesses to use (within a limited scope).
E-mail: info@ephilpower.com



Warranty Card

This warranty card is to be retained and provided in case of the warranty claim.

Customer Name* (Printed):			
Customer Name (Signature):			
Telephone:		E-Mail*:	
Address*:			
Zip Code*:		City(County):	
State (Province/Region):		Country:	
Date of Purchase*:		Engine Serial Number:	
Where is your engine purchased from?			
Order Number:			

Problem description*:

ENGINE MODEL CODE



X040TP

(By signing this card, I agree to abide by the terms and the conditions of warranty declaration and terms. And I understand that the manufacturer has the right of final interpretation for the warranty.)

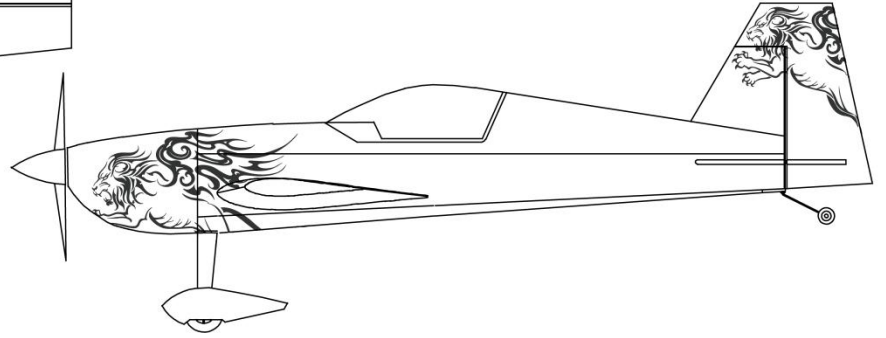
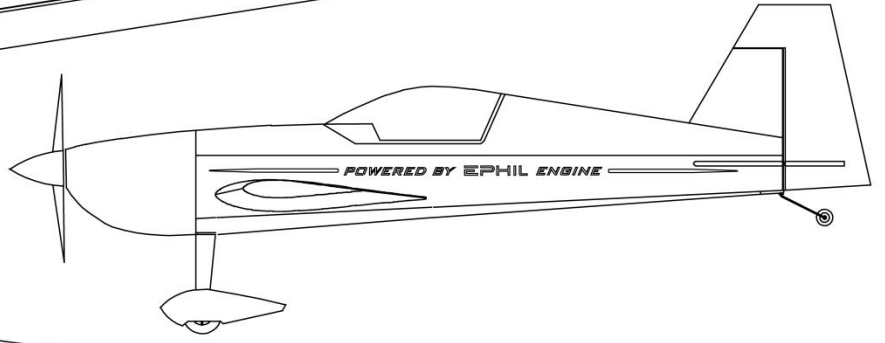
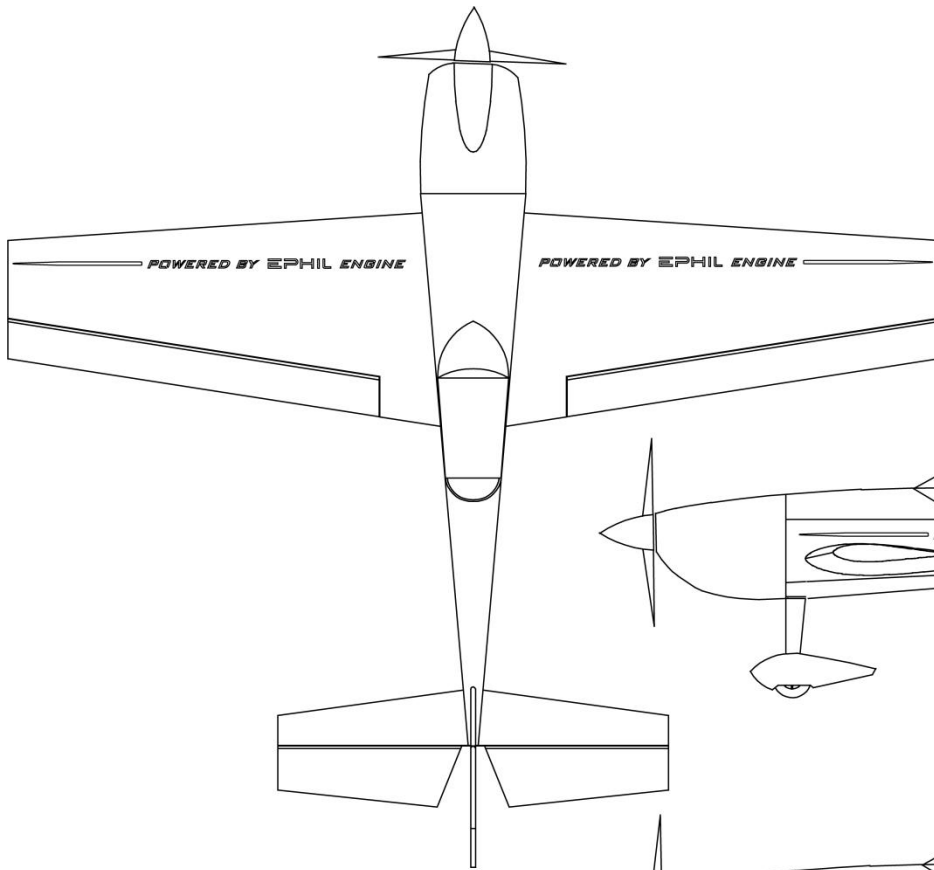



WWW.EPHILPOWER.COM