



# EME 60 Gasoline Engine User Manual



## **SAFETY INSTRUCTIONS**

- © Thank you for purchasing EME 60 gasoline Engine. We at EME always strive to product reliable engines that bring you pleasure of flight. It is vitally important to read **SAFETY INSTRUCTIONS** very carefully before operating EME 60 gasoline engine.
- © Gasoline is **POISONOUS** and **HIGHLY FLAMMABLE**. Do not allow it contact with the eyes or mouth. Always store it in a cool and dark place, out of the reach of children. It is possible that the fuel can damage your health. Always store and transport it in an antistatic container.
- © **DO NOT** start the engine in an area containing loose gravel or sand. **NEVER** start the engine indoor.
- © For their safety, keep all onlookers (especially young children) well back (at least 5 meters behind the engine). **NEVER** stand at the front of, or to the side of the engine when it is running.
- © Check and tighten your propeller and spinner before one day's flights. **DO NOT** use a Nylon propeller. **NEVER** try to repair and use a broken propeller.

## Specifications

Item	Technique Data
Displacement	60 cc
Weight	1390 g/Engine, 180 g/Muffler, 140 g/Ignition Module
Compression Ratio	7.6
Power	6.2 HP @ 7200 RPM
Idle RPM	1350 RPM
Practical RPM	1350 ~ 7500 RPM
Thrust 1	16.2 kgf (50~200 m Altitude)
Thrust 2	14.7 kgf (1800~2000 m Altitude)
Spark Plug	EME / NGK CM6
Ignition Voltage	4.8 V to 6 V
Fuel	91~93 Octane, 1:30~1:35 Mix Ratio

## Package Contents

Item	Quantity
Engine	1 pcs
Muffler	1 pcs
Ignition Module	1 pcs
Spark Plug	1 pcs
Stand-off Spacer	4 pcs
Spacer Screw	M5*15 (front), 4 pcs M5*22 (rear), 4 pcs
Spacer Washer	M5*4 for rear mounting spacers
Muffler Screw	2 pcs
Muffler Gasket	1 pcs
Manual	1 pcs
Logo Tag	1 pcs

## **Mounting the Engine**

- ◎ The engine should be mounted on a firewall that will in turn mount to the fuselage. The firewall should have enough strength to prevent engine vibration. The firewall should be made from at least 6 mm aircraft plywood.
- ◎ A tension free mounting is obligatory. The mounting surface should be even. Mount the engine with high tensile bolts and stand-off spacers, which are provided with the engine.
- ◎ Proper cooling is vital for gasoline engines. Intake area should be more than 65\*80 mm. Outlet area should be at least as 3 times as the intake area.

## **Ignition Information**

- ◎ Install the ignition module with sufficient anti-vibration, at least 100 mm away from the engine and in the place where not affected by engine exhaust heat and radiation heat.
- ◎ Do not share the battery with receiver. Use separated battery for ignition module. Equip an ON/OFF switch between the ignition module and battery. Use a high quality switch such as Futaba HSW-J or HSW-L heavy duty switch. Standard size receiver switches are not recommended.
- ◎ Install the ignition module and make its cable, switch and battery be as far as possible away from the servos, the receiver battery and the receiver.
- ◎ Install the spark plug cap on the plug securely. Protect the signal wire and high voltage spark plug cable from rubbing against fiberglass, sharp edges of wood and metal of the fuselage.

## Propeller Option

- ◎ A wooden propeller, as well as a carbon fiber propeller, is suggested. Do not use a nylon propeller. XOAR, HAWK, VESS and MENZ wooden propellers are suggested . XOAR, FALCON, RED SWORD and MEJZLIK carbon propellers are also suggested. Since there are so many good propellers on the market, your choice is not limited to the brands mentioned above.
- ◎ 23\*10, 24\*8 and 24\*10 two-blade propellers are suggested. With the propellers mentioned above, the peak RPM range should be 6,300 to 7,100 RPM.
- ◎ 21\*12 and 22\*10 three-blade propellers are suggested for scale purpose.

## Starting Process

- ◎ Close the choke and switch on the ignition switch. Advance the throttle 1/8~1/4 from full closed.
- ◎ Flip the propeller quickly until explosive sound can be heard.
- ◎ After propeller stopping, open the choke and set the throttle to idle position(or a little higher). Flip the propeller again until the engine starts. **BE CAREFUL!**
- ◎ Warm up the engine for about 30~45 seconds. Now the engine is ready for flight.

## Fuel & Break-in

- ◎ Use low to middle octane gas for break-in. Use the propeller same as flight.
- ◎ Use a 2-stroke petroleum based oil with a mixture of 25:1 to 30:1. Synthetic oil is **NOT** suggested in break-in process.
- ◎ With this fuel mixture ratio and regular needle setting, run the engine for 1~2 hours. Too rich needle setting, which may cause misfiring or erratic running, is not suggested.
- ◎ After break-in, you can use a 2-stroke synthetic oil with a mixture of 30:1 to 35:1.

## Needle Adjustments

- ◎ A Walbro HDA carburetor or equal carburetor is adopted. The carburetor has two needles, which are low speed needle and high speed needle. Low speed needle is effective through the high speed range, while the high speed needle is not effective in the low throttle status. Both needles are effective in the mid speed, but the low speed needle is more effective. Default position of high speed needle is  $1 \frac{5}{8}$  turns from full closed, as well as low speed needle is  $1 \frac{2}{3}$  turns.
- ◎ For fine setting, please tune the engine for maximum RPM with the high speed needle by using a tachometer. Then richen the high speed needle until the motor runs 100~200 RPM less than the maximum RPM. Now the engine is slightly rich on the high speed needle.
- ◎ Furthermore, keep the engine at idle for 45~60 seconds. Check that the idle RPM remains constant or not. If the RPM drops and the engine stops finally, the speed needle should be too rich. Lean it until stable idle status is achieved. Then check the transition with advancing throttle quickly. The engine should make steady power immediately without any hesitation. If the engine sounds hesitated to response, please check the low speed needle again.

## Mounting Pattern

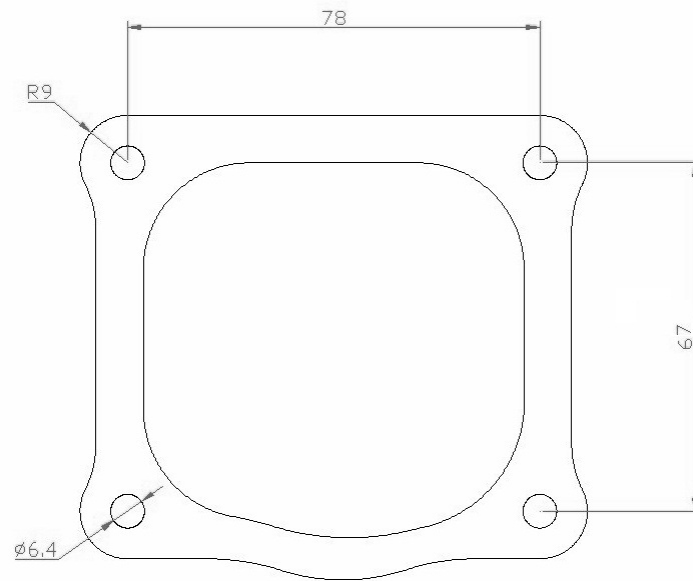

## Carburetor Introduction

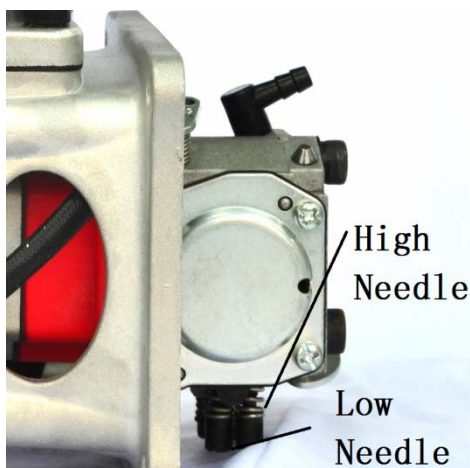
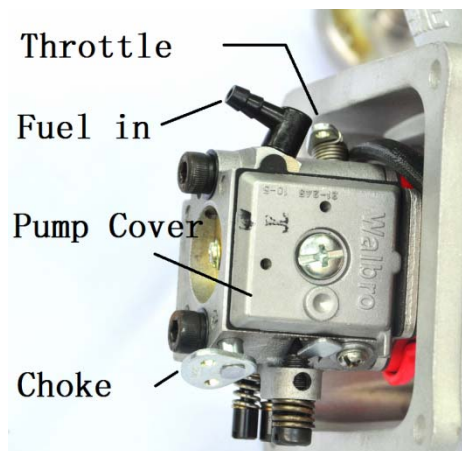

## **Engine Maintenance**

- ◎ **NEVER** mix different kinds of 2 stroke oils for flying. Before changing oils, please clean the carburetor with pure gasoline.
- ◎ To avoid incident carburetor failure, please remove carburetor pump cover and clean the built-in fuel filter every 50~100 flights.
- ◎ It is advisable to maintain or replace piston, piston ring, crankshaft, needle/ball bearing and spark plug every 300~500 flights, according to engine status. Please consult your local dealer.
- ◎ Please examine and clean your engine very carefully after a crash. If it is damaged, please consult your local dealer to fix the engine. Repair due to crash is **NOT** free.

## **WARRANTY**

- ◎ EME 60 engine and ignition module are covered with 18 months warranty by Eagle Master Engine since purchasing date.
- ◎ The warranty covers defects of materials and assemble issues.
- ◎ Damage by improper installing, operation is not covered by warranty.
- ◎ Damage by using improper fuel is not covered by warranty.
- ◎ Damage by incident crash is not covered by warranty.

